

PLEASE CHECK WWW.MOLEX.COM FOR LATEST PART INFORMATION

Part Number: **0039000430**
Status: **Active**
Overview: [minifit_jr](#)
Description: 4.20mm (.165") Pitch Mini-Fit™ Crimp Terminal, Male, Brass, Gold (Au) Contact Plating, Lead-free, 18-24 AWG, Reel

Documents:

Drawing (PDF)	Product Specification PS-5556-001 (PDF)
Test Summary (PDF)	Product Specification PS-5556-002 (PDF)
Product Specification PS-51010-007 (PDF)	Product Specification PS-5556-003 (PDF)
Product Specification PS-52034-005 (PDF)	RoHS Certificate of Compliance (PDF)

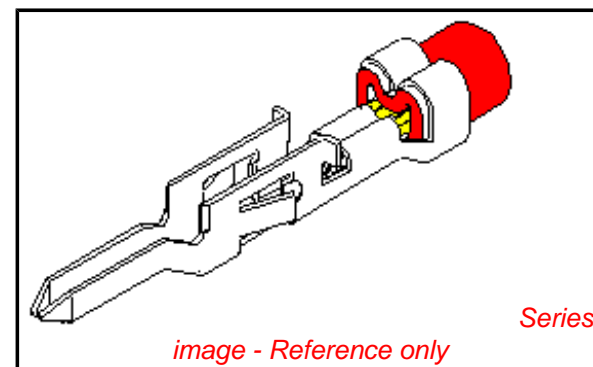

General

Product Family	Crimp Terminals
Series	5558
Crimp Quality Equipment	Yes
Overview	minifit_jr
Product Name	Mini-Fit®

Physical

Durability (mating cycles max)	30
Gender	Male
Material - Metal	Brass
Material - Plating Mating	Gold
Material - Plating Termination	Tin
Packaging Type	Reel
Termination Interface: Style	Crimp or Compression
Wire Insulation Diameter	1.30-3.10mm (.051-.122")
Wire Size AWG	18, 20, 22, 24
Wire Size mm²	N/A

Electrical

Current - Maximum per Contact	9A
Voltage - Maximum	600V

Material Info

Old Part Number	5558GS7F
-----------------	----------

Reference - Drawing Numbers

Product Specification	PS-51010-007, PS-52034-005, PS-5556-001, PS-5556-002, PS-5556-003
Sales Drawing	SD-5558-002
Test Summary	TS-5556-002

EU RoHS

ELV and RoHS Compliant
REACH SVHC
 Not Reviewed
Halogen-Free Status
 Not Reviewed

China RoHS



Need more information on product environmental compliance?

Email productcompliance@molex.com
 For a multiple part number RoHS Certificate of Compliance, [click here](#)

Please visit the [Contact Us](#) section for any non-product compliance questions.

Search Parts in this Series

5558Series

Mates With

5556 Mini-Fit™ Crimp Terminal

Use With

5559 Mini-Fit Jr.™ Plug Housing

Application Tooling | FAQ

Tooling specifications and manuals are found by selecting the products below. Crimp Height Specifications are then contained in the Application Tooling Specification document.

Global

Description	Product #
FineAdjust™	0639015600
Applicator for Mini-Fit Jr.™, Mini-Fit HCS™ Crimp Terminals, 18-24 AWG and smaller insulation	
T2 Terminator Die	0639102600

FineAdjust™ Applicator	<u>0639002600</u>
FineAdjust™ Applicator, Small Insulation	<u>0639002900</u>
T2 Terminator Tooling Die	<u>0639102900</u>
Extraction Tool	<u>0011030044</u>
Hand Crimp Tool for Mini-Fit™ Jr. Male and Female Crimp Terminals, 16-24 AWG	<u>0638190900</u>

This document was generated on 06/01/2010

PLEASE CHECK WWW.MOLEX.COM FOR LATEST PART INFORMATION

10 9 8 7 6 5 4 3 2 1

NOTES

1. MATERIAL: SEE CHART
2. FINISH: SEE CHART
3. PRODUCT SPECIFICATION: PS-5556-001, PS-5556-002, PS-5556-003.
4. PACKAGING SPECIFICATION: PK-5558-001 FOR CHAIN
PK-5556-003 FOR LOOSE
5. MATES WITH TERMINAL: 5556 SERIES.
6. APPLICABLE HOUSING: 5559, 30068, 42475 SERIES.
7. THE NUMBER OF SERRATIONS TO BE ONE FOR WIRE RANGE #22-28.
8. WHEN TERMINALS ARE INSTALLED IN THE HOUSING THE WIRES ARE TO BE DRESSED IN SUCH A MANNER TO ALLOW THE TERMINALS TO FLOAT FREELY IN THE POCKET.
9. THIS TERMINAL IS DESIGNED FOR SINGLE WIRE CRIMPING.
10. PART CONFORMS TO CLASS "B" REQUIREMENTS OF COSMETIC SPECIFICATION PS-45499-002.

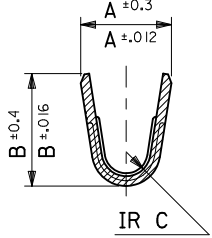
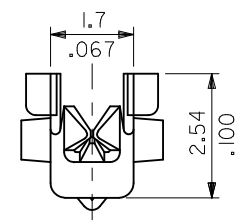
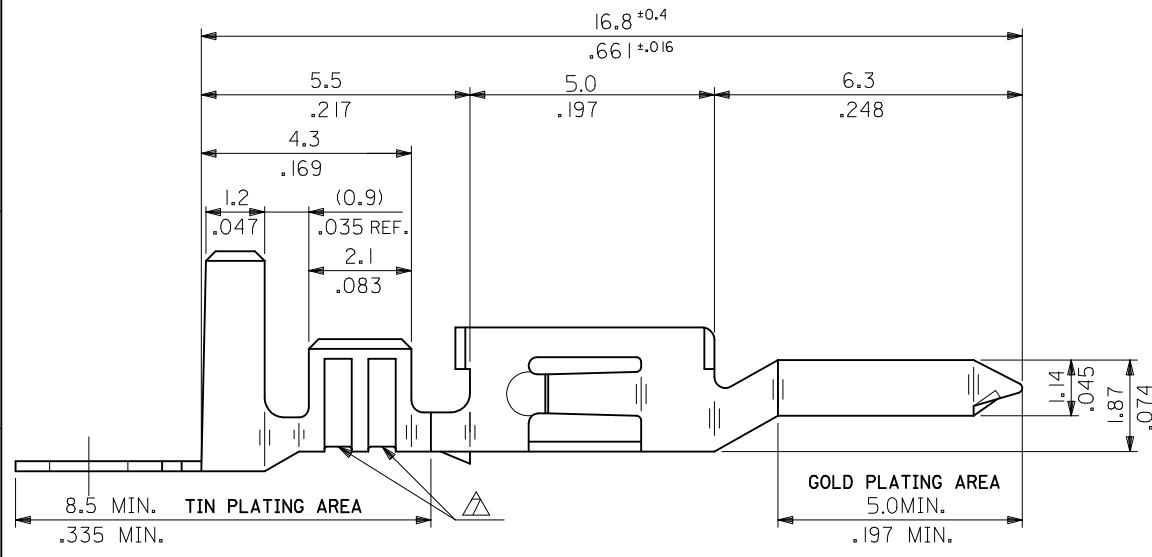
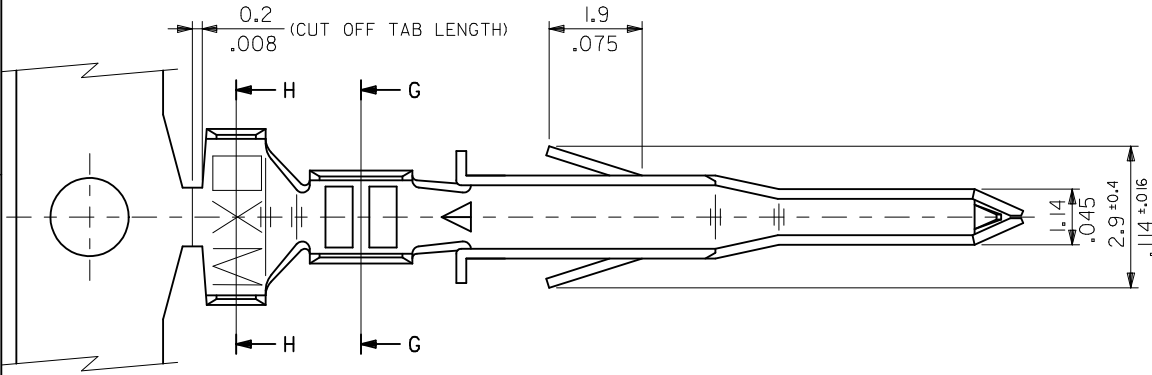

SECT. G-G

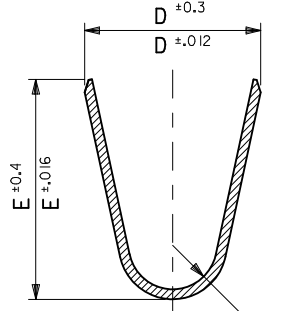

SECT. H-H

UPDATE NOTES EC NO: UCP2010-2478 DRWN: J JAGUILAR 2010/04/06 CHKD: JBELL '92/05/21 APPR: FSMITH 2010/04/09	QUALITY SYMBOLS F7=0 F7=0 F7=0	GENERAL TOLERANCES (UNLESS SPECIFIED)		DIMENSION STYLE	SCALE	DESIGN UNITS	THIRD ANGLE PROJECTION	
				MM/IN	10:1	METRIC		
				DRAWN BY	DATE	TITLE		
				CHECKED BY	DATE	MOLEX INCORPORATED		
		ANGULAR ± 3 °		APPROVED BY	DATE	DOCUMENT NO.		
		DRAFT WHERE APPLICABLE MUST REMAIN WITHIN DIMENSIONS		FSMITH	2010/04/09	SD-5558-002		
				MATERIAL NO.	SEE CHART		SHEET NO.	
				SIZE B	THIS DRAWING CONTAINS INFORMATION THAT IS PROPRIETARY TO MOLEX INCORPORATED AND SHOULD NOT BE USED WITHOUT WRITTEN PERMISSION		1 OF 2	

9 8 7 6 5 4 3 2 1

PHOSPHOR BRONZE	SELECTIVE GOLD 0.76µm /30m.i. MIN. AND SELECTIVE TIN 2.03µm /80m.i. MIN. OVER NICKEL 1.27µm /50m.i. MIN.	0.9 .035	4.5 .177	3.6 .142	0.6 .024	2.7 .106	2.3 .091	∅ 3.1 .122 MAX.	# 16	39-00-0224	5558 PBGS3L	LOOSE
		0.6 .024	2.3 .091	2.3 .091	0.4 .016	1.65 .065	1.8 .071	∅ 0.9-1.8 .035-.071	#22-28	↑ -0223	↑ PBGS3	CHAIN
		0.6 .024	2.3 .091	2.3 .091	0.4 .016	1.65 .065	1.8 .071	∅ 0.9-1.8 .035-.071	#22-28	-0222	PBGS2L	LOOSE
		0.9 .035	4.5 .177	3.6 .142	0.5 .020	2.3 .091	1.9 .075	∅ 1.3-3.1 .051-.122	# 18-24	-0221	PBGS2	CHAIN
		0.9 .035	4.5 .177	3.6 .142	0.5 .020	2.3 .091	1.9 .075	∅ 1.3-3.1 .051-.122	# 18-24	-0220	PBGS1	LOOSE
		0.9 .035	4.5 .177	3.6 .142	0.5 .020	2.3 .091	1.9 .075	∅ 1.3-3.1 .051-.122	# 18-24	-0219	PBGS	CHAIN
		0.9 .035	4.5 .177	3.6 .142	0.6 .024	2.7 .106	2.3 .091	∅ 3.1 .122 MAX.	# 16	-0148	GS9L	LOOSE
		0.6 .024	2.3 .091	2.3 .091	0.4 .016	1.65 .065	1.8 .071	∅ 0.9-1.8 .035-.071	#22-28	↓ -0147	GS9	CHAIN
		0.6 .024	2.3 .091	2.3 .091	0.4 .016	1.65 .065	1.8 .071	∅ 0.9-1.8 .035-.071	#22-28	↓ -0146	GS8L	LOOSE
		0.9 .035	4.5 .177	3.6 .142	0.5 .020	2.3 .091	1.9 .075	∅ 1.3-3.1 .051-.122	# 18-24	39-00-0145	GS8	CHAIN
		0.9 .035	4.5 .177	3.6 .142	0.5 .020	2.3 .091	1.9 .075	∅ 1.3-3.1 .051-.122	# 18-24	40-13-0854	GS7L	LOOSE
		0.9 .035	4.5 .177	3.6 .142	0.6 .024	2.7 .106	2.3 .091	∅ 3.1 .122 MAX.	# 16	40-13-0853	GS7	CHAIN
BRASS	SELECTIVE GOLD 1.27µm /50m.i. MIN. AND SELECTIVE TIN 2.54µm /100m.i. MIN. OVER NICKEL 1.27µm /50m.i. MIN.	0.9 .035	4.5 .177	3.6 .142	0.6 .024	2.7 .106	2.3 .091	∅ 3.1 .122 MAX.	# 16	39-00-0100	GS6L	LOOSE
		0.6 .024	2.3 .091	2.3 .091	0.4 .016	1.65 .065	1.8 .071	∅ 0.9-1.8 .035-.071	#22-28	↑ -0099	GS6	CHAIN
		0.6 .024	2.3 .091	2.3 .091	0.4 .016	1.65 .065	1.8 .071	∅ 0.9-1.8 .035-.071	#22-28	-0098	GS5L	LOOSE
		0.6 .024	2.3 .091	2.3 .091	0.4 .016	1.65 .065	1.8 .071	∅ 0.9-1.8 .035-.071	#22-28	-0097	GS5	CHAIN
		0.9 .035	4.5 .177	3.6 .142	0.5 .020	2.3 .091	1.9 .075	∅ 1.3-3.1 .051-.122	# 18-24	-0076	GS4L	LOOSE
		0.9 .035	4.5 .177	3.6 .142	0.5 .020	2.3 .091	1.9 .075	∅ 1.3-3.1 .051-.122	# 18-24	-0075	GS4	CHAIN
	SELECTIVE GOLD 0.76µm /30m.i. MIN. AND SELECTIVE TIN 2.03µm /80m.i. MIN. OVER NICKEL 1.27µm /50m.i. MIN.	0.9 .035	4.5 .177	3.6 .142	0.6 .024	2.7 .106	2.3 .091	∅ 3.1 .122 MAX.	# 16	-0096	GS3L	LOOSE
		0.6 .024	2.3 .091	2.3 .091	0.4 .016	1.65 .065	1.8 .071	∅ 0.9-1.8 .035-.071	#22-28	-0095	GS3	CHAIN
		0.6 .024	2.3 .091	2.3 .091	0.4 .016	1.65 .065	1.8 .071	∅ 0.9-1.8 .035-.071	#22-28	-0433	GS2L7F	LOOSE
		0.6 .024	2.3 .091	2.3 .091	0.4 .016	1.65 .065	1.8 .071	∅ 0.9-1.8 .035-.071	#22-28	-0432	GS27F	CHAIN
		0.9 .035	4.5 .177	3.6 .142	0.5 .020	2.3 .091	1.9 .075	∅ 1.3-3.1 .051-.122	# 18-24	↓ -0431	↓ GSL7F	LOOSE
		0.9 .035	4.5 .177	3.6 .142	0.5 .020	2.3 .091	1.9 .075	∅ 1.3-3.1 .051-.122	# 18-24	39-00-0430	5558 GS7F	CHAIN
MATERIAL	FINISH	F	E	D	C	B	A	INS. RANGE	WIRE RANGE	EDP NO.	ENG NO.	FORM

UPDATE TITLE BLOCK EC NO: UCP2010-2478 DRWN: J JAGUILAR 2010/04/06 CHKD: JBELL '92/05/21 APPR: FSMITH 2010/04/09 REV E1	QUALITY SYMBOLS ∇=0 ∇=0 ∇=0	GENERAL TOLERANCES (UNLESS SPECIFIED)		DIMENSION STYLE		SCALE	DESIGN UNITS	THIRD ANGLE PROJECTION		
		mm		INCH		MM/IN	10:1	METRIC		
		DRAWN BY		DATE		CHECKED BY		DATE		MOLEX INCORPORATED SD-5558-002
		H.HIRAMOTO		'91/03/13		M.FUKUSHIMA		'92/05/21		
APPROVED BY		DATE		MATERIAL NO.		DOCUMENT NO.		SHEET NO.		
FSMITH		2010/04/09		SEE CHART		SD-5558-002		2 OF 2		
DRAFT WHERE APPLICABLE MUST REMAIN WITHIN DIMENSIONS THIS DRAWING CONTAINS INFORMATION THAT IS PROPRIETARY TO MOLEX INCORPORATED AND SHOULD NOT BE USED WITHOUT WRITTEN PERMISSION										